

# Experimental Investigate Effects of Cutting tools on Surface Roughness and MRR of EN31 (Alloy Steel) Turning Operation on CNC Machine

**Delvadiya Parth<sup>1</sup>, Prof. Ankit Darji<sup>2</sup>**

<sup>1</sup>P.G. Student, <sup>2</sup>Assistant Professor

LDRP Institute of Technology & Research, Gandhinagar, Gujarat, India

---

International Journal of Engineering & Technology Research

Volume 3, Issue 3, May-June, 2015, pp. 36-45

ISSN Online: 2347-4904, Print: 2347-8292, DOA : 20062015

© IASTER 2015, www.iaster.com

---



## ABSTRACT

*This paper introduces an experimental work of material removal rate and roughness characteristics of surface roughness create CNC turning on EN-31 composite steel (alloy steel). In this test essential three machining parameters is developed based on experiment the experiment carries out consider machining parameters cutting speed, feed rate, depth of cut. Three types of cutting tool turning inserts are use for turning on EN-31 material. Insert material is carbide at relative other coating material it is physical vapor deposition, chemical vapor deposition. Analysis of experiment adequacy of the models of material removal rate & surface roughness has been established with the analysis of variance (ANOVA) throw present.*

**Keywords:** CNC Turning Operation, EN-31, Surface Roughness, Material Removal Rate, ANOVA.

## INTRODUCTION

The test of current machining businesses is mostly centered around the accomplishment of high caliber in term of work piece dimensional precision, surface completion, high creation rate, less wear on the cutting apparatuses, economy of machining as far as expense sparing and increment of the execution of the item with diminished ecological .The system behind the arrangement of surface roughness in CNC turning procedure is extremely dynamic, complicated, and process dependent. A few components will impact the last surface Roughness in CNC operations, for example, controllable variables (cutting speed, feed rate and depth of cut) and wild elements (apparatus geometry and material properties of both instrument and workpiece).

The components that impact surface completion are machining parameters, instrument and work piece material properties and cutting conditions. For instance, in Turning operation the surface completion relies on upon cutting speed, feed rate, depth of cut, cutting fluid, tool nose radius lubrication of the cutting tool, machine vibrations, tool wear and on the mechanical and other properties of the material being machined.CNC turning procedure parameters are classified by, Machining parameters, Work piece, machine instrument and cutting methodology parameters as indicated in below Figure (1).

Machining is any of various processes in which a piece of raw material is cut into a desired final shape and size by a controlled material-removal process. The material removal rate (MRR) in turning operations is the volume of material/metal that is evacuated every unit time in mm<sup>3</sup>/min. For each revolution of the work piece, a ring shaped layer of arterial is removed.

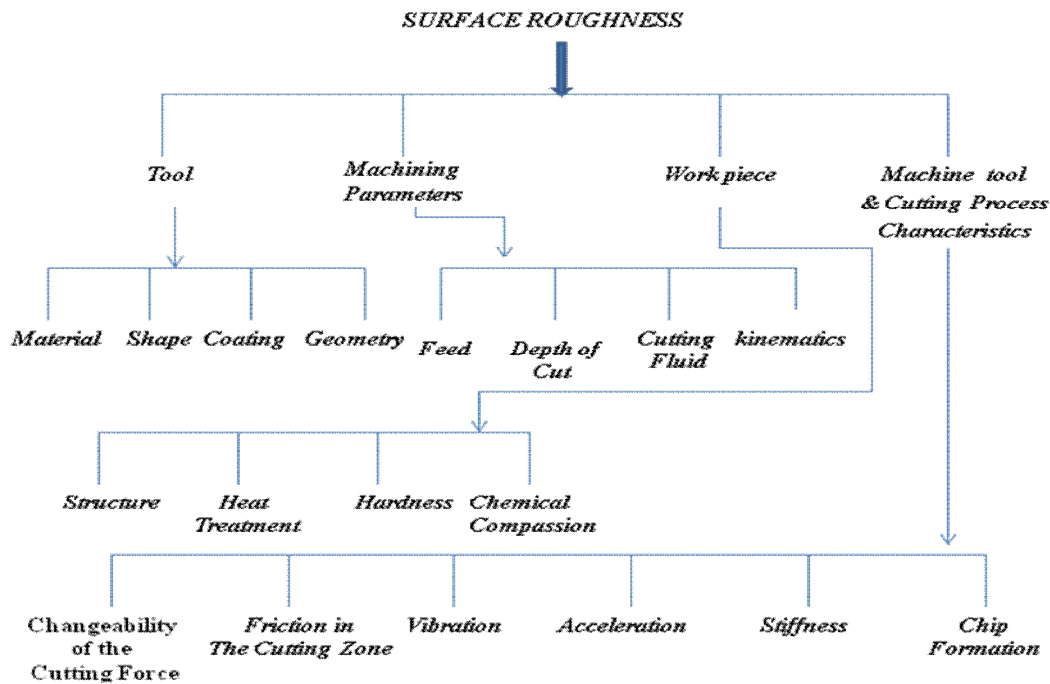

Fig. 1 Parameters Affects the Surface Roughness

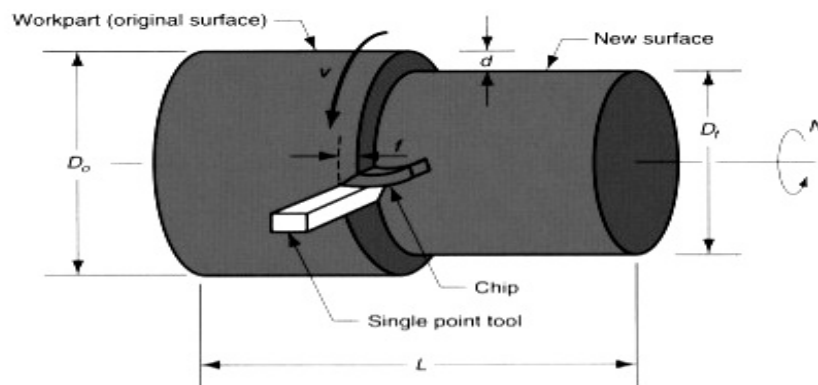

Fig. 2 Turning Operation

$$MRR = (v \cdot f \cdot d \times 1000) \text{ in mm}^3/\text{min}$$

$$MRR = \frac{W_i - W_f}{\rho \cdot t}$$

v- Cutting speed m/min, f- Feed rate mm/min, d- Final diameter of the job in mm  $W_i$ - Initial weight of work piece in gram,  $W_f$ - Final weight of work piece in gram,  $\rho$ - Density of alloy steel, t- Machining time in minute.

## EXPERIMENTAL CONDITIONS

**1. Test specimen:** The test was directed utilizing one work piece material EN-31. The tests work piece relative measurement was a length 200 MM and Ø32 MM. The essential utilized of EN-31 material as Ball and Roller Bearings, Spinning tool, Beading Rolls, Punches and Dies. By its character this sort of steel has high opposing nature against wear and can be utilized for segments which are subjected to every abrasion, wear or high surface loading. The chemical composition and mechanical properties of the selected work piece is shown as in table 1 and table 2 respectively.

**Table1. Chemical Composition of EN 31 Alloy Steel**

C%	Si%	Mn%	S%	P%
0.90 - 1.20	0.30 - 0.75	0.10 - 0.35	0.040	0.040

**Table2. Mechanical Properties of EN 31 Alloy Steel**

Bulk Modulus	Shear Modulus	Elastic Modulus	Poisson's Ratio	Hardness Rockwell C
140 Gpa	80 Gpa	190 GPa	0.30	0.20

**2. Machine tool:** Computer Numerical Control (CNC) is one in which the capacities and movements of a machine tool are controlled by method for an arranged system containing coded alphanumeric information. CNC Can control the movements of the workpiece or tool, the input parameters such as feed, depth of cut, speed, and the functions such as turning spindle on/off, turning coolant on/off. Machining experiment has been performed on a high rigid CNC lathe (JOBBER XL, India) equipped with variable spindle speed from 50 to 3500 rpm and 16KW maximum spindle power with Control System Fanuc 0i-Mate-TD shown in Fig. 3) under dry environment.



**Fig. 3 CNC Machine**

**1.3 3. Cutting Inserts:** To build the life of carbide additions, they are some of the time coated. Four such coatings are TiN (titanium nitride), TiC (titanium carbide), Ti(C)N (titanium carbide-nitride), and TiAlN (titanium aluminum nitride). Most coatings by and large build a tool' hardness and/or lubricity. A coating allows the cutting edge of a tool to cleanly pass through the material without having the material gall or stick to it. The coating also helps to decrease the temperature associated with the cutting process and increase the life of the tool. The coating is normally saved by means of thermal CVD and, for specific applications, with the mechanical PVD strategy at lower temperatures.

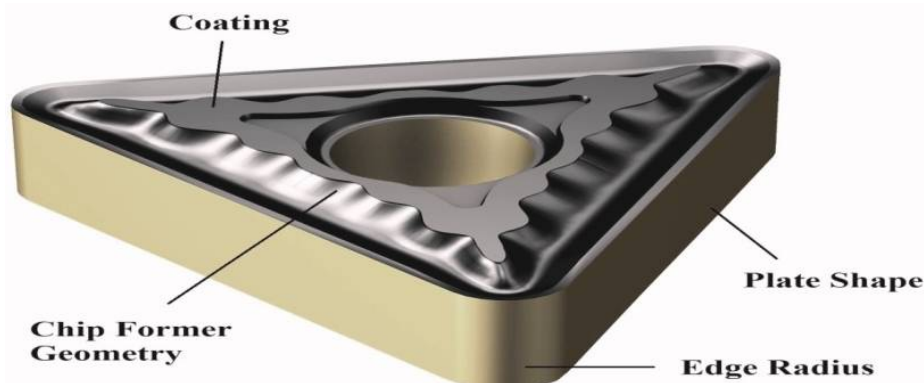

**Fig.4 CNC Turning Insert**

**A) Chemical Vapor Deposition (CVD)** is an atmosphere controlled process conducted at elevated temperatures (~1925° F) in a CVD reactor. During this process, thin-film coatings are formed as the result of reactions between various gaseous phases and the heated surface of substrates within the CVD reactor. As different gases are transported through the reactor, distinct coating layers are formed on the tooling substrate. For example, TiN is formed as a result of the following

Chemical response:  $TiCl_4 + N_2 + H_2 \xrightarrow{1000^\circ C} TiN + 4 HCl + H_2$ . Titanium carbide (TiC) is structured as the consequence of the following substance response:  $TiCl_4 + CH_4 + H_2 \xrightarrow{1030^\circ C} TiC + 4 HCl + H_2$ . The last result of these responses is a hard, wear-resisting coating that displays a chemical and metallurgical security to the substrate. CVD coatings give superb resistant to the sorts of wear and irritating regularly seen amid numerous metal-framing applications. CVD coatings are utilized as a part of many manufacturing applications as a wear-resistant coating: carbide milling and turning inserts, wear components, some plastic processing tools, etc. The most widely recognized application for CVD covering is for metal-framing tools.

**B) Physical Vapor Deposition (PVD)** coatings are shaped at generally low temperatures (400-600°C). The methodology includes the evaporation of a metal which responds with, for example, nitrogen to structure a hard nitride coating on the cutting device surface. PVD coatings add wear resistant to an evaluation because of their compressive stresses additionally include edge toughness and crack resistance. The main PVD-coating constituents are described below. Current coatings are combination of these constituents in sequenced layers and/or lamellar coatings. Lamellar coatings have various slight layers, in the nanometer range, which make the coating considerably harder.

In the event of PVD TiAlN coating, the change in the slicing execution is because of the oxidation resistance of TiAlN properties at higher temperature. High wear resistance even at high temperatures is the exceptional property of TiAlN, a trademark that makes this covering suitable to cut rough work piece material, for example, cast iron, aluminum silicon combinations and composite materials at high speeds.

**2.4 Cutting conditions:** The cutting condition for finish hard turning dry turning operation under higher parametric condition is shown in table:

**Table 3. Process Parameters of Turning Operation**

Process Parameters with their Values at Three Levels				
Factor	Process parameters	Level 1	Level 2	Level 3
A	Cutting speed (v) m/min	100	150	200
B	Feed rate (f) mm/rev.	0.125	0.150	0.175
C	Depth of cut (d) mm	0.2	0.3	0.4

**2.5 Testing Instrument:** The arithmetic average surface roughness (Ra) of the work piece is measured by SURFTEST SJ 201P surface roughness tester (shown in Fig.5), where the cutoff length and assessment length was fixed as 0.8 mm and 4 mm respectively. The instrument was calibrated using a standard calibration block prior to the measurements. The measurement was taken at four locations (90° apart) around the circumference of the workpieces and repeated twice at each point on the face of the machined surface and the average values reported for the response.



Fig.5 Surface Roughness Tester

### DESIGN OF EXPERIMENT

In this study, cutting speed, feed rate, depth of cut and cutting fluids were considered as machining parameters. An L27 Taguchi orthogonal array was used as the experimental design. The parameters investigated and the levels were indicated in table Experimental layout and desired Response:

Orthogonal array (L27)									
				P.V.D Insert		C.V.D Insert		Uncoated Insert	
Ex. No.	Cutting Speed (v) m/min	Feed (f) mm/rev.	D.O.C (d) mm	MRR mm <sup>3</sup> /min	Ra (µm)	MRR mm <sup>3</sup> /min	Ra (µm)	MRR mm <sup>3</sup> /min	Ra (µm)
1	100	0.125	0.2	1697.4	1.31	650.78	1.78	1301.57	0.81
2	100	0.125	0.3	3245.3	1.17	1301.57	1.55	1301.57	0.85
3	100	0.125	0.4	4057.1	1.25	650.78	1.44	1301.57	0.9
4	100	0.15	0.2	1858.04	1.66	1526.25	1.69	2289.37	1.42
5	100	0.15	0.3	3716.09	1.73	1526.25	1.61	1526.25	1.16
6	100	0.15	0.4	4645.1	1.77	1526.25	1.56	3052.5	1.12
7	100	0.175	0.2	2177.6	1.02	1793.07	2.19	1844.67	1.69
8	100	0.175	0.3	4837.9	2.34	896.53	2.11	2767.01	1.77
9	100	0.175	0.4	6047.4	2.28	2689.6	2.46	1844.67	1.82
10	150	0.125	0.2	2564.1	1.3	949.66	1.62	949.68	1.01
11	150	0.125	0.3	4273.5	1.39	949.66	1.6	2849	1.01
12	150	0.125	0.4	4273.5	1.38	1899.33	1.34	4748.33	0.93
13	150	0.15	0.2	1980.4	1.99	2279.2	1.69	1139.6	1.14
14	150	0.15	0.3	4169.2	1.81	2279.2	1.56	3418.8	1.19
15	150	0.15	0.4	4169.2	1.76	2279.2	1.61	4558.4	1.38
16	150	0.175	0.2	3561.2	2.49	2619.1	2.34	3981.52	1.72
17	150	0.175	0.3	4748.3	2.39	1309.55	2.31	5308.7	1.83

18	150	0.175	0.4	5935.4	2.42	5238.2	2.3	2654.35	1.57
19	200	0.125	0.2	1295	0.76	1232.74	1.65	1282.05	0.88
20	200	0.125	0.3	7770	0.99	2465.48	1.52	2564.1	0.95
21	200	0.125	0.4	9065	0.93	1232.74	1.31	3846.15	0.8
22	200	0.15	0.2	7695.3	0.97	1544.64	1.65	1539.07	1.03
23	200	0.15	0.3	1077.5	0.98	4633.92	1.79	4617.23	1.28
24	200	0.15	0.4	6156.3	1.31	6178.56	1.82	6156.3	1.09
25	200	0.175	0.2	9290.2	1.62	1758.64	2.12	3512.46	1.56
26	200	0.175	0.3	1114.2	1.84	1758.64	2.32	5268.7	1.77
27	200	0.175	0.4	1300.3	1.64	5275.93	2.37	5268.7	1.58

Ra- Arithmetic average of absolute values for surface roughness

## RESULTS AND DISCUSSION

Uses of MINITAB to present experimental variation relative to Surface roughness value difference and Material removal rate.

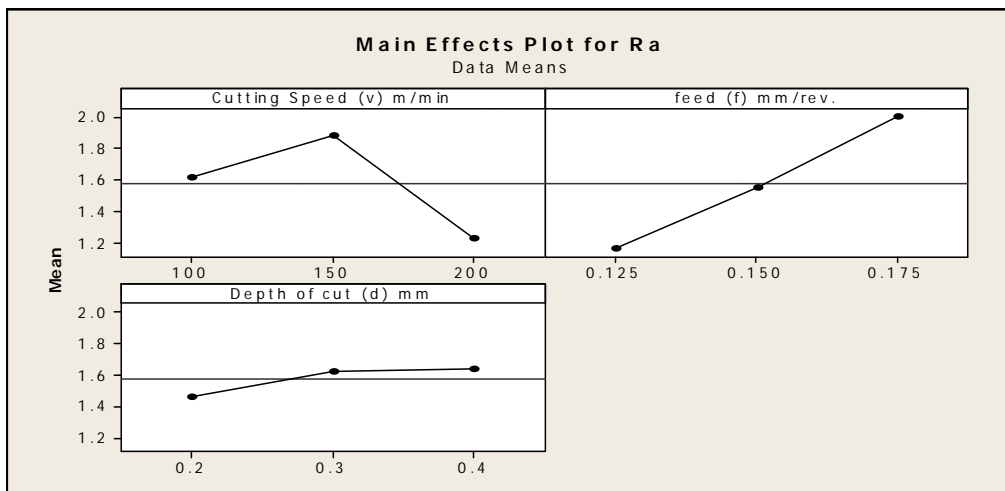

Fig.6 Ra versus Cutting Speed (v) m/min, feed (f) mm/rev, Depth of cut mm (PVD coated)

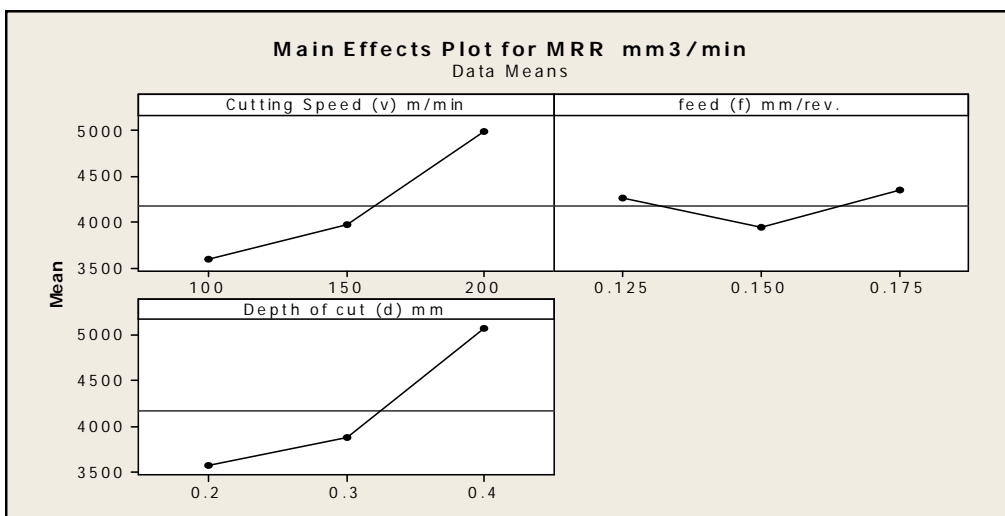

Fig.7 MRR mm<sup>3</sup>/min versus Cutting Speed (v) m/min, feed (f) mm/rev, Depth of cut mm (PVD coated)

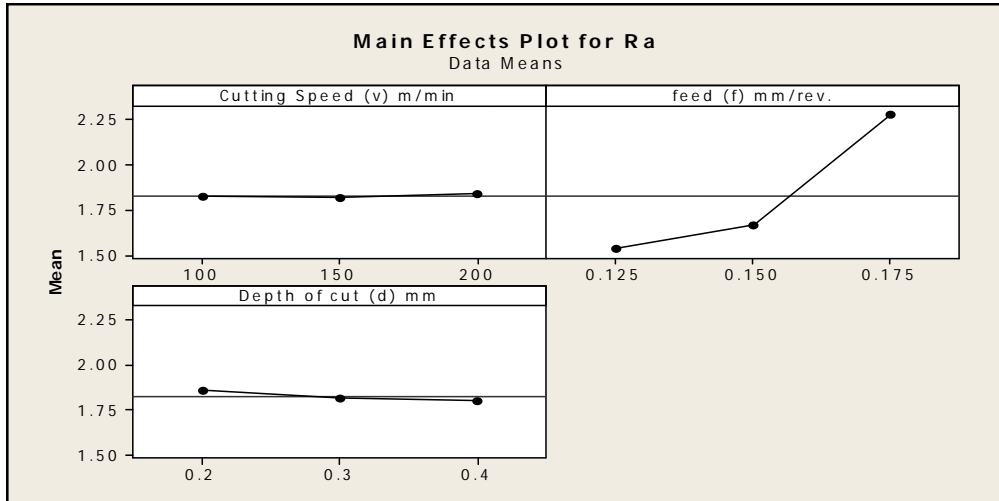

Fig.8 Ra versus Speed Cutting Speed (v) m/min, feed (f) mm/rev, Depth of cut (CVD coated)

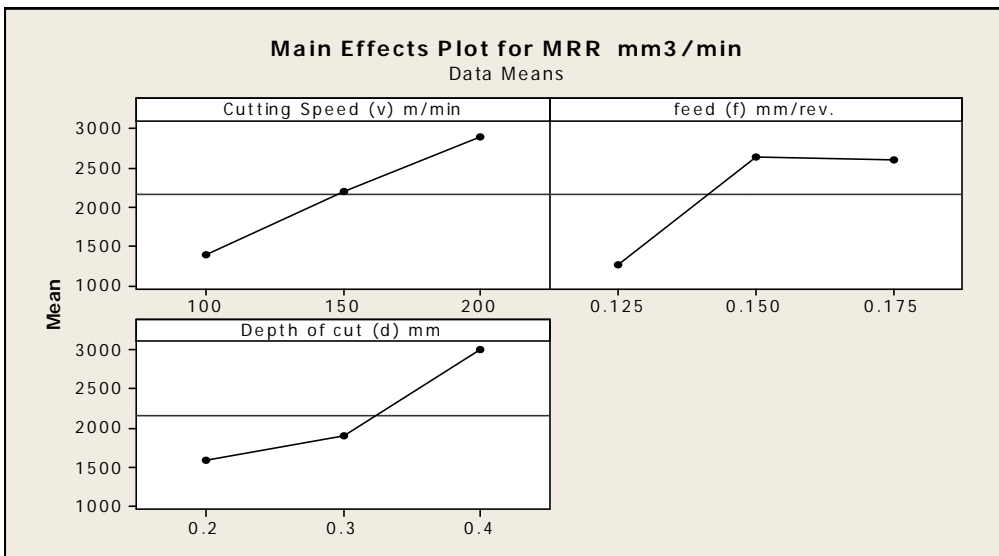

Fig.9 MRR mm<sup>3</sup>/min versus Cutting Speed (v) m/min, feed (f) mm/rev, Depth of cut (CVD coated)

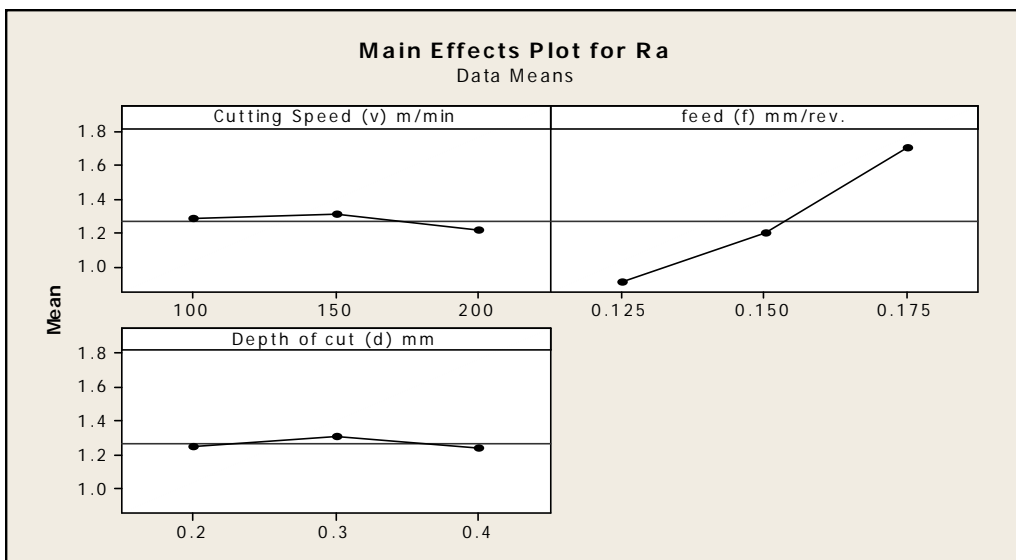

Fig.10 Ra versus Speed Cutting Speed (v) m/min, feed (f) mm/rev, Depth of cut (Uncoated)

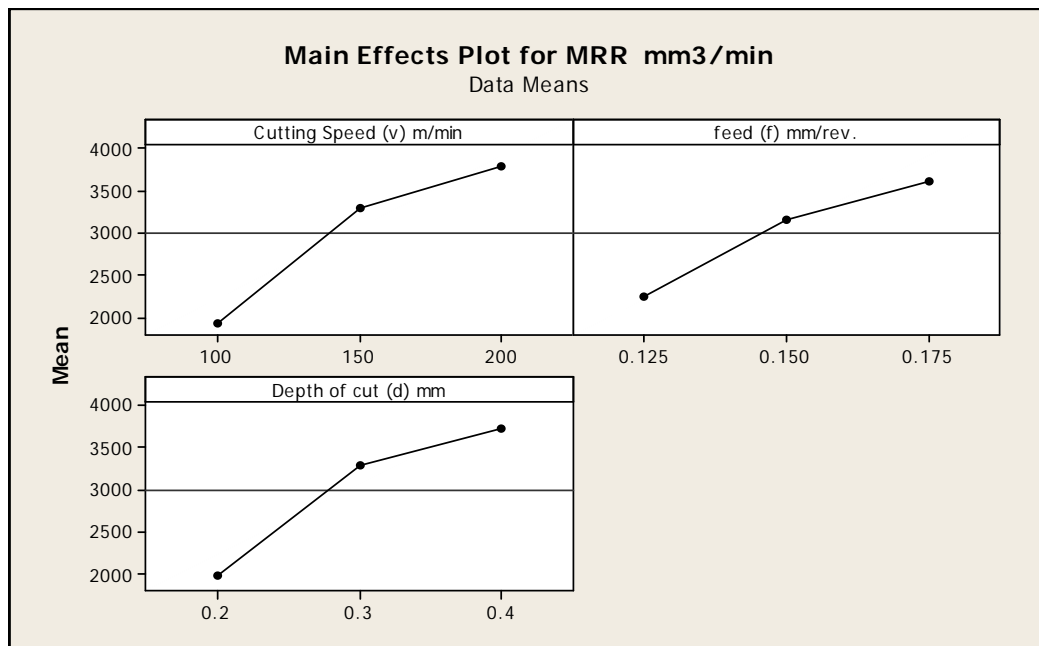

Fig.11 MRR mm<sup>3</sup>/min versus Cutting Speed (v) m/min, feed (f) mm/rev, Depth of cut mm (Uncoated)

- Taguchi method cannot judge and determine effect of individual parameters on entire process while percentage contribution of individual parameters can be well determined using ANOVA. MINITAB software of ANOVA module was employed to investigate effect of process parameters (Cutting speed, feed rate, depth of cut). The significant parameters influencing the MRR and Ra in the turning process with coated inserts and uncoated are determined using analysis of variance (ANOVA). It helps in formally testing the significance of all main factors and their interactions by comparing the mean square against an estimate of the experimental errors at specific confidence levels
- Use **Fully Nested ANOVA** to determine whether the means of two or more groups differ when all the factors are nested.

SS- Sum of square, DF- Degree of freedom, MS- Mean square, Total (%) – contribution

Table.4 Analysis of Variance for Ra versus Cutting Speed (v) m/min, feed (f) mm/rev, Depth of cut mm

Analysis of Variance for Roughness (Ra) $\mu\text{m}$													
		PVD Coated				CVD Coated				Uncoated			
Source	DF	SS	MS	F	P	SS	MS	F	P	SS	MS	F	P
Cutting Speed (v) m/min	2	1.9493	0.9747	1.688	0.262	0.0022	0.0011	0.002	0.998	0.0416	0.0208	0.042	0.959
Feed (f) mm/rev.	6	3.4647	0.5775	7.998	0	2.9098	0.485	28.652	0	2.9489	0.4915	42.465	0
Depth of cut (d) mm	18	1.2996	0.0722			0.3047	0.0169			0.2083	0.0116		
Total	26	6.7137				3.2166				3.1989			

**Table.5 Variance Components for Ra versus Cutting Speed (v) m/min, feed (f) mm/rev, Depth of cut mm**

Variance Components for Roughness (Ra) $\mu\text{m}$									
	PVD Coated			CVD Coated			Uncoated		
Source	Var Comp.	Total % of	StDev	Var Comp.	Total % of	StDev	Var Comp.	Total % of	StDev
Cutting Speed (v) m/min	0.044	15.5	0.21	-0.054*	0	0	-0.052*	0	0
Feed (f) mm/rev	0.168	59.15	0.41	0.156	90.21	0.395	0.16	93.25	0.4
Depth of cut (d) mm	0.072	25.36	0.269	0.017	9.79	0.13	0.012	6.75	0.108
<b>Total</b>	<b>0.285</b>		<b>0.534</b>	<b>0.173</b>		<b>0.416</b>	<b>0.172</b>		<b>0.414</b>

**Table.6 Analysis of Variance for MRR versus Cutting Speed (v) m/min, feed (f) mm/rev, Depth of cut mm**

Analysis of Variance for MRR mm <sup>3</sup> /min													
	PVD Coated					CVD Coated				Uncoated			
Source	DF	SS	MS	F	P	SS	MS	F	P	SS	MS	F	P
Cutting Speed (v) m/min	2	9.26E+06	4.63E+06	2.195	0.193	1.02E+07	5.09E+06	1.983	0.218	1.69E+07	8.45E+06	4.556	0.063
Feed (f) mm/rev.	6	1.27E+07	2.11E+06	0.304	0.927	1.54E+07	2.56E+06	1.495	0.236	1.11E+07	1.85E+06	0.955	0.482
Depth of cut (d) mm	18	1.25E+08	6.94E+06			3.09E+07	1.72E+06			3.49E+07	1.94E+06		
<b>Total</b>	<b>26</b>	<b>1.47E+08</b>				<b>5.64E+07</b>				<b>6.29E+07</b>			

**Table.7 Variance Components for MRR versus Cutting Speed (v) m/min, feed (f) mm/rev, Depth of cut mm**

Variance Components for MRR mm <sup>3</sup> /min									
	PVD Coated			CVD Coated			Uncoated		
Source	Var Comp.	Total % of	StDev	Var Comp.	Total % of	StDev	Var Comp.	Total % of	StDev
Cutting Speed (v) m/min	279931.311	3.88	529.085	280172.36	12.29	529.313	732519.833	27.4	855.874
Feed (f) mm/rev.	-1.61040E+06*	0	0	282887.38	12.41	531.872	-28846.214*	0	0
Depth of cut (d) mm	6939934.139	96.12	2634.375	1716057	75.29	1309.984	1940434.778	72.6	1392.995
<b>Total</b>	<b>7219865.45</b>		<b>2686.981</b>	<b>2279116.8</b>		<b>1509.674</b>	<b>2672954.611</b>		<b>1634.917</b>

## CONCLUSION

In this paper, a study had been carried out to the process parameters viz. Cutting Speed, Feed and Depth of Cut with respect to material removal rate (MRR) and Surface rate in CNC lathe of alloy steel (EN-31) using MINITAB. Also, three coated and uncoated carbide turning insert used in experiments. The effect of process parameters on material removal rate and Surface rate was investigated. L27 orthogonal array was used to conduct the experiments. The analysis showed that Depth of Cut had the most significant effect on MRR followed by Feed. With an increase in Depth of Cut MRR increased

in the studied range. Optimum cutting parameter combination was for maximum MRR at P.V.D coated insert throw found out. And analysis showed that Feed rate had the most significant effect on Surface rate followed by Cutting speed. With an increase in feed rate finer irregularities of the surface texture values, (Ra) reduce in the studied range. So, use of uncoated insert throw turning measures the finer irregularities of the surface texture values.

## REFERENCES

- [1] Sayak Mukherjee, Anurag Kamal, Optimization of Material Removal Rate During Turning of SAE 1020 Material in CNC Lathe using Taguchi Technique. *Procedia Engg.* 97 (2014) 29 – 35.
- [2] Shreemoy Kumar Nayak, Jatin Kumar Patro, Multi-Objective Optimization of Machining Parameters During Dry Turning of AISI 304 Austenitic Stainless Steel Using Grey Relational Analysis. *Procedia Materials Science* 6 (2014) 701 – 708.
- [3] Meenu Gupta, Investigation of surface roughness and MRR for turning of UD-GFRP using PCA and Taguchi method. *Engg. Science and Tech., an International Journal* (2014) 1e12
- [4] Ch. Srinivasa Rao, Analysis of Cutting Forces for Different Work Materials and Tool Material: Effect of Rake Angle in Turning Process *Int.Jur. Scientific Research.*(2014) 2277 – 8179.
- [5] C R Barik, Parametric Effect and Optimization of Surface Roughness of EN 31 In CNC Dry Turning. *International Journal Of Lean Thinking* (2011)
- [6] Ashok Kumar Sahoo, Experimental Investigations on Machinability aspects in Finish Hard Turning of AISI 4340 Steel Using Uncoated and Multilayer Coated Carbide Inserts. *Measurement* 45 (2012) 2153–2165
- [7] Aman Aggarwal, Optimizing Power Consumption for CNC Turned Parts Using Response Surface Methodology and Taguchi's Technique—A Comparative Analysis. *Journal of materials processing technology* 200 (2008) 373–384
- [8] M. Kaladhar, Determination of Optimum Process Parameters During Turning of Aisi 304 Austenitic Stainless Steels Using Taguchi Method and ANOVA. *International Journal of Lean Thinking V- 3, Issue 1* (2012)
- [9] Gaurav Bartarya, Effect of Cutting Parameters on Cutting Force and Surface Roughness During Finish Hard Turning AISI52100 Grade Steel. *Procedia CIRP* 1 (2012) 651 – 656
- [10] Awadhesh Pal, Machinability Assessment through Experimental Investigation during Hard and Soft Turning of Hardened Steel. *Procedia Materials Science* 6 (2014) 80 – 91
- [11] Gabriel C. Benga, Turning of Hardened 100Cr6 Bearing Steel with Ceramic and PCBN Cutting Tools. *Journal of Materials Processing Technology* 143–144 (2003) 237–241
- [12] W. Grzesik Surface Finish Generated in Hard Turning of Quenched Alloy Steel Parts Using Conventional and Wiper Ceramic Inserts. *International Journal of Machine Tools & Manufacture* 46 (2006) 1988–1995
- [13] Harsh Y Valera, Experimental Investigation of Surface Roughness and Power Consumption in Turning Operation of EN 31 Alloy Steel. *Procedia Technology* 14 (2014) 528 – 534
- [14] V. García Navas, Surface Integrity of AISI 4150 (50CrMo4) Steel Turned with different types of Cooling-Lubrication. *Procedia CIRP* 13 (2014) 97 – 102.