

Blockchain based Secured Framework for Road Traffic Management using Fog Computing

Dr.S.Nirmala¹, Dr.M.Sathya², Dr.M.Senthilmurugan³, R.Chinnaiyan⁴, Dr.Stalin Alex⁵

¹Professor, Department of CSE, AMC Engineering College, Bangalore, Karnataka, India

²Associate Professor, Department of ISE, AMC Engineering College, Bangalore, Karnataka, India

³Professor & Director (Admin), Dept. of MCA, AVC Engineering College, Mannampandal- Mayiladuthurai, Tamil Nadu, India

⁴Professor & Head, Department MCA, AMC Engineering College, Bangalore, Karnataka, India

⁵ Associate Professor, Department of CST (DS), Jain Deemed to be University, Bangalore, Karnataka, India

Date of Submission: 21st October 2021 Revised: 11th November 2021 Accepted: 9th December 2021

How to Cite: Dr. S.Nirmala et.al. (2021). Blockchain based Secured Framework for Road Traffic Management using Fog Computing. *International Journal of Computational Intelligence in Control* 13(2)

Abstract

Nowadays, technology proceeds at rapid rate and the number of smart gadgets continues to grow substantially. As a result, there is a need for ubiquitous platforms to support an interconnected, heterogeneous, and distributed network of devices. This network of objects is commonly called the Internet of Things. This research paper combines the Blockchain and IoT with other related technologies for secured road traffic management. It includes blockchain, cloud computing, wireless sensor networks and fog computing. The research paper mainly focuses on the role of blockchain and fog computing in IoT-based secured framework for road traffic management. The Internet of Things concept is normally associated with cloud computing. The research paper proposes blockchain based Secured Framework for road Traffic Management using Fog Computing and Internet of Things with a novel layer called Fog layer into the architectural framework for traffic environment. Here the fog computing plays an intermediary responsibility between the IoT layer and the cloud layer. The use of fog based model is to reduce latency and the total cost for the implementation of the system.

Keywords: Internet of Things, Fog Computing, Cloud, Traffic Management, Blockchain

1. INTRODUCTION

The IoT is significant because an object that can represent itself digitally, becomes something greater than the object by itself. No longer does the object just relate to the process; it now connects to surrounding objects and database data, permitting “big data” analytics and insights. In particular, “things” might communicate autonomously with other things and other devices, such as sensors in manufacturing environments or an activity tracker with a smart phone.

The IoT technology has evolved from the convergence of wireless technologies, micro electromechanical systems, micro-services and the internet. This convergence has torn down the walls between operational technology and information technology, allowing unstructured machine-generated data to be analyzed for insights that will drive improvements. The Internet of Things (IoT) is the network of devices or things that can automatically connect to the Internet and talk to each other without any external intervention. This technology uses numerous sensors to collect data from the surroundings. The output devices for the Internet of things is called actuators. The IoT has many challenges or issues due to its limited power and storage. Security, reliability, privacy and performance are considered to be the major challenges of IoT.

Due to the heterogeneity of the IoT devices, the development of new applications is a tedious job. Sensors and other devices in the internet of things generate high volume of stream data. These sensor data are basically big data. Data transmission between the cloud and the sensor need high bandwidth. Fog computing was introduced to solve the above-said issues.

The network major, Cisco, coined the term Fog. The relevant computing paradigm is called fog computing. Fog computing is providing data processing and storage services to the end users. The major difference is that fog computing stores sensor generated locally in the fog rather than moving to the cloud.

1.1 BACKGROUND

Fog computing is a newer distributed computing paradigm. The fog computing architecture builds on the fundamental capabilities of the cloud. Each and every basic element in this architecture is known as a fog node. Fog nodes are connected the fog server using wired or unwired

transmission media. The purpose of fog computing in the IoT is to improve efficiency, performance and reduce the amount of data transferred to the cloud for processing, analysis and storage. Therefore, the data collected by sensors will be sent to network edge devices for processing and temporary storage, instead of sending them into the cloud, thus reducing network traffic and latency. The concept of the internet of things offers better solutions for many existing systems as in Figure 1 like Home, Transport, Community and Industries. If the internet of things is used in intelligent transporting system, authority can track location each vehicle and monitor its movement.

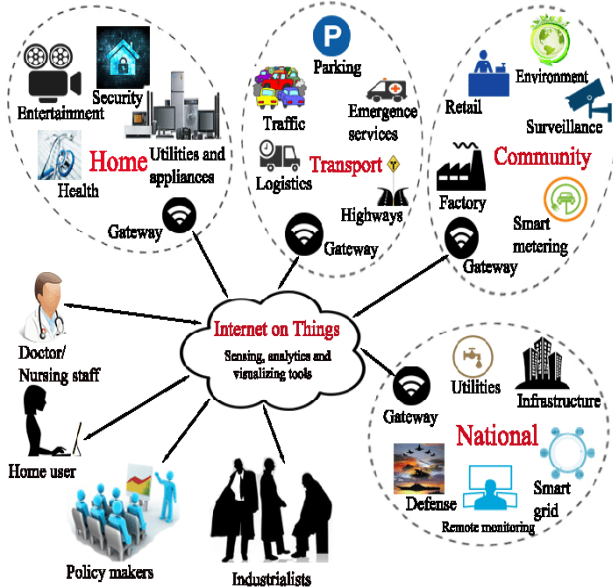

Figure 1: Use cases of IoT

The system also predicts its future location for possible accident. Earlier, the identifiable interoperable objects with RFIDs were referred as the Internet of Thing (IoT). Later the Internet of Things is related to more technologies such sensors, actuators and other sensing devices including GPS devices. The internet of things (IoT) is defined as a dynamic network infrastructure with self-configuring capabilities. The IoT is based on communication protocols. Each and every thing or object has its own unique identities and physical attributes. It also uses smart interface for providing services. In other words, the IoT is a global network containing a number of connected devices. These devices are having sensors, actuators, communication facilities. RFID is the basic technology for the internet of things. In RFID technology, the identification information is sent by the microchips using wireless transmission. The data from RFID chips are read by the reader. It is possible to identify, track and monitor any devices. In addition, wireless sensor network seems to another foundational technology. A WSN has many interconnected smart sensors to sense and monitor the environment.

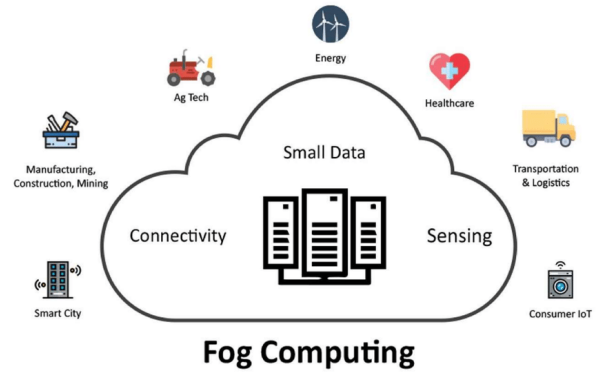

Figure 2: Applications of Fog Computing

The various applications areas of fog computing is shown in Figure.2 Major Application areas of Fog Computing which includes Smart City , Manufacturing, Construction, Mining, Agriculture, Energy, Healthcare, Transportation, Logistics and Consumer Internet of Things.

2. PROBLEM STATEMENT

Safe transportation of passengers is the key target of any transportation framework. Roadways are considered to be the most secure method of mass transportation. It is very essential to ensure the safety and security of the travelling public. For the cause, the roadways need to be made accident-free. Therefore, the proposed research paper deals with construction and implementation of IoT based intelligent framework for traffic management using fog computing.

2.1 PROPOSED METHODOLOGY

The growth of the field of IoT is very fast as the number of smart devices attached to the internet is increasing day by day. This field opens enormous opportunities for the birth of numerous distributed wireless applications. The internet of things is fit for applications that require high mobility, geographical distribution, and quick response. Therefore, real-world applications like smart grid, smart city, and traffic management can be implemented with the help of IoT. Road traffic management is highly time-sensitive problem that needs to be addressed to save lives of passengers and the general public. It is very tedious to handle the traffic management in the roadways since accidents may occur at various places in the roadways transport system. Here, an IoT-based Intelligent Framework for vehicle traffic management system as in Figure 7 is implemented. Traffic congestion is one of the issues in roadways traffic management. Due to traffic congestion, travel might be increased resulting difficulty to the passengers. On the other hand, a proper traffic control system has been required to prevent road accidents. Figure 8 depicts the IoT Based Intelligent Framework for traffic Management using Fog Computing. Each node of the

model contains Raspberry Pi, signal LED board, camera, IR sensor and RFID device.

3. IMPLEMENTATION

The following components are required for the implementation of Intelligent Traffic Management

1. Raspberry Pi
2. Wi-Fi
3. Pi camera
4. IR sensor
5. RFID device
6. LED lights

3.1 Raspberry Pi



Figure 3: Raspberry Pi

The basic IoT device is the Raspberry Pi. It is a small sized single board computer. It support operating systems like Debian and Raspbian and can be programmed using Python and Scratch. The device can easily be connected to monitor and the standard input devices of keyboard and mouse are also supported by the device. The Raspberry Pi has been introduced in three generations. Each generation kit is available in different models. In the IoT-based intelligent traffic control system, Raspberry Pi 3 Model B kit is used as the IoT device. It contains Broacom SoC (System on Chip) and GPU. Its RAM can be extended up to 1GB. Raspbian OS is running from the SD card. Figure 4 shows the Raspberry Pi 3 Model B kit.

3.2 Wi-Fi

The term Wi-Fi stands for wireless fidelity which is a popular wireless standard. The Wi-Fi base station usually refers to the wireless access point for computers. Basically, it is a low-power transmitter or wireless router that can communicate with nearby computers and other wireless devices. Here, Wi-Fi connects IoT devices with the cloud and sensors

3.3 Camera



Figure 4: Pi Camera

For continuous monitoring, either conventional video camera or Pi camera can be used in the traffic management system. Pi Camera is the HD camera used for taking picture and video. This camera is attached to the Raspberry Pi kit via CSI port. Figure 5 shows a 5 MP Pi camera. Infrared sensor simply called IR sensor is a sensing device where infrared ray is used for transmission. Figure 6.5 shows the image of an IR sensor. It consists of two elements: transmitter and receiver. Normally, IR sensors are utilized for two purposes. The sensor will measure the heart emitter by an object detect the motion.

3.4 IR sensor

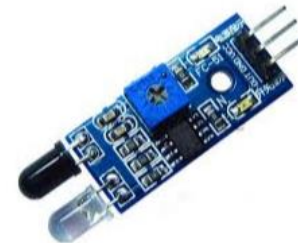

Figure 5 IR Sensor

An Infrared (IR) sensor is an electronic device that emits in order to sense some aspects of the environments. These sensors measure only infrared radiation. A infrared sensor is an electronic sensor that measures infrared (IR) light radiating from objects.

3.5 RFID device

RFID is an abbreviation of radio frequency identification. It is a wireless technology through which encoded digital data in a small chip called RFID tag are recognized by its reader. This communication technology is working using electromagnetic waves. Figure shows how RFID technology functions in the IoT environment. Each RFID tag is attached to its corresponding antenna. RFID tags sends data at a particular frequency. The corresponding antenna captures the data and passes it to the reader. RFID technologies can be classified into two types namely, near and far technology. A near RFID reader uses a coil by which one has to pass AC current and generate a magnetic field. RFID tag with smaller coil produces a potential because of the ambient changes in the magnetic field. This

voltage is then coupled with a capacitor to accumulate a charge, which then powers up the tag chip. The tag can then produce a small magnetic field to the digital data. This encoded form of data is recognized by the corresponding reader. Here radio waves with various frequencies are used for data communication between the RFID antenna and the tags. RFID tags are also of two types: active tags and passive tags. Every active tag has its own power source. But in the case of passive, there is a different phenomenon. Passive tags get power from the EM waves emitted by the nearest RFID reader. The RFID technology can cover up to hundreds of meters

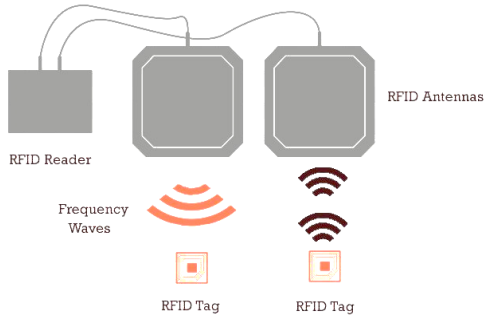

Figure 6: RFID Technology with RFID Tag , Antenna and Reader

3.6 LED lights

Light emitting diodes are called LEDs. The intelligent traffic control system uses only LED lights to indicate the traffic signal to the vehicles. There are various types of LEDs available. To display three colors, three LED lamps need to be utilized. The infrared sensors will give high output whenever heavy traffic and some obstacle in the track. Pi camera continuously monitoring the vehicles for any toward incident. If it happens, the Python code will alert the road authorities. RFID tags placed in the vehicles , near roads on signal poles and road signals are used to identify the current location of the vehicles and other conditions in the surroundings.

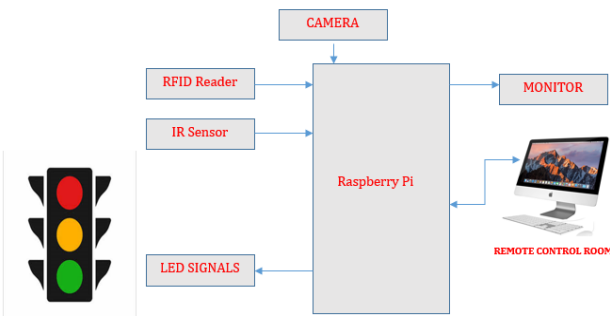

Figure 7: IoT Based Intelligent Framework for Traffic Management

Thus the IoT-based system would help reduce the vehicles traffic congestion. By this system time management for signal lights is done which will reduce the road traffic congestion problem. The proposed fog based model will add another layer between IoT devices and the cloud. The goal

of using fog computing is to enhance the performance and storage cost.

PROPOSED FRAMEWORK

This proposed research paper proposes a layered architecture of intelligent framework for road traffic management using fog computing. The new fog-based model is applied to the road traffic management application only because the roadways is highly accident prone mode of transport. Road accidents may occur at any time and any place due human error. The Figure shows the layered model of the proposed vehicles traffic management framework. It consists of four layers:

1. Cloud Layer
2. Fog Layer
3. IoT Device Layer
4. Sensor Layer

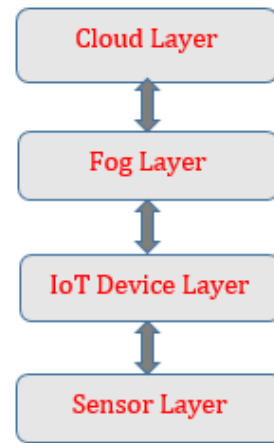

Figure 8 : Layered architecture of intelligent framework for Traffic Management

4.1 Cloud Layer:

It is the uppermost layer of the model. In this layer, the cloud services are available for the user. This layer is responsible for receiving the result of the programs executing on the edge of the network (fog layer) and provides high level applications for intelligent traffic management.

4.2 Fog Layer

This is the new layer added in the fog computing platform for handling traffic data and ensuring smooth transportation. It gathers data from the corresponding IoT devices in the below layer.

4.3 IoT Device Layer

The third layer from the top is called the IoT device layer. It has numerous IoT devices to process the sensor data. The layer may contain any of Raspberry Pi, Arduino, Tessel, Spark and Galileo kits.

4.4.Sensor Layer

The bottommost layer of the framework will be the sensor. The sensors are tiny electronic devices that collect data from the surroundings and send it to the nearest IoT device for processing. There are various types of sensors such as temperature sensor, MEMS sensor, ultrasonic sensor, presence sensor, etc. This layer may also include actuators for traffic signaling and alarming purposes

5. BLOCKCHAIN

Multichain is an open source used for developing this blockchain system. It helps us to create different nodes for devices which will get communicated through blockchain network as mentioned in Figure 4.

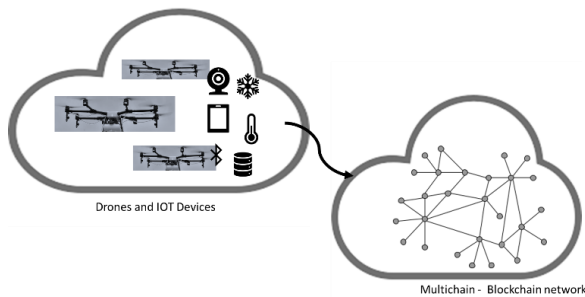

Figure 11: Blockchain Communication

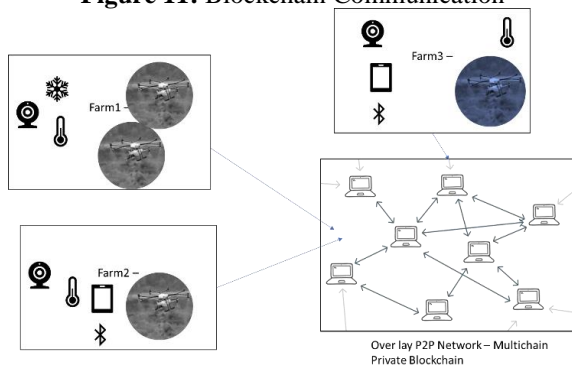

Figure 12: Blockchain based Connected Traffic Management Framework

Each traffic management framework has its set of IOT devices, drones as mentioned in Figure 5 and which will communicate with its local immutable register deployed. It processes all incoming and outgoing transactions and utilize a shared key for location communication with IOT devices and local storage (i.e. one of the multichain node). This will be repeated for other sets and ensure all the devices are securely authenticated. Overlay is P2P (Peer to Peer) network which keeps the same copy of the ledger across different nodes with in the blockchain network. By default Multichain uses consensus protocol and it doesn't need a mining as it's a private blockchain network specific to that framework. The below example shows how we create blockchain and start interact with IOT devices and drones.

Step 1: Create Blockchain in Multichain

We will create a new blockchain named `traffic_framework 1` On the `plant1` server,

```
multichain-util create agro_farm traffic_framework 1
```

To view the blockchain's settings of traffic framework

```
cat ~/.multichain/traffic_framework/params.dat
```

Connecting to Blockchain network

```
multichaind traffic_framework 1@[192.168.1.100]:[5432]
```

The blockchain was successfully initialized, but we do not have permission to connect. we should also be shown a message containing an address in this node's wallet

```
multichain-cli traffic_framework
```

```
grant 192.168.1.120 connect
```

```
connect
```

```
connect
```

we can repeat the same process for other server that we planned to setup in the blockchain.

Step2: Create Stream to use for data storage and retrieval.

```
create stream traffic_framework_stream
```

```
publish traffic_framework_stream key1
```

```
2253253616d2064617461
```

The txid of the stream item is returned.

```
subscribe traffic_framework_stream
```

```
liststreamitems traffic_framework_stream
```

We want the second server to be allowed to publish to the stream on the first server:

```
grant 192.168.1.121. send
```

```
grant 192.168.1.121 traffic_framework_stream. write
```

Step 3: Create Assets

We can create new asset and send it between nodes, asset on this node with 1000 units, each of which can be subdivided into 100 parts, sending it to itself. Also, we created a drone unique identifier (DUID) and kept in the

`traffic_framework_stream_asset1`.

```
issue 192.168.1.121 traffic_framework_stream_asset1
```

```
10000 0.01
```

```
sendwithdata 192.168.1.121. {"agro_farm1_asset1
```

```
\"}:"125}"
```

```
{\"for\":\" traffic_framework_stream_stream1
```

```
\"key\":\"transfer\",\"drone1_duid\":\"953051\"}"
```

To start block validation between the nodes. In the case of a permissioned MultiChain blockchain, consensus is based on block signatures and a customizable round-robin consensus scheme for IOT kind of transactions.

```
grant 192.168.1.121. mine – Here no real mining takes
```

```
place as its private blockchain
```

Multichain Explorer is a tool for browsing the Transactions

in multichain network It looks something like below

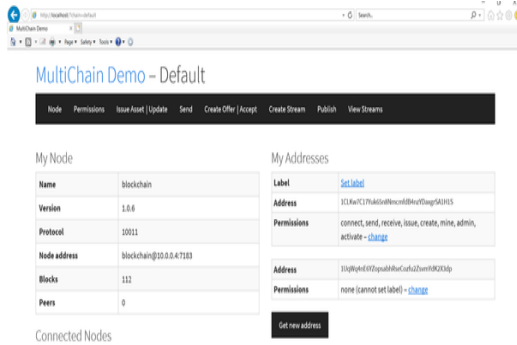

Figure 13. MultiChain-in-blockchain

CLOUD ENVIRONMENT

We will use Amazon IOT Hub or Azure IOT Hub to collect the data from IOT Edge. The edge will have necessary device id and event id to communicate with respective IOT Hub or Event hub to push the transactions. we use MQTT based communication between IOT Edge to cloud hub.

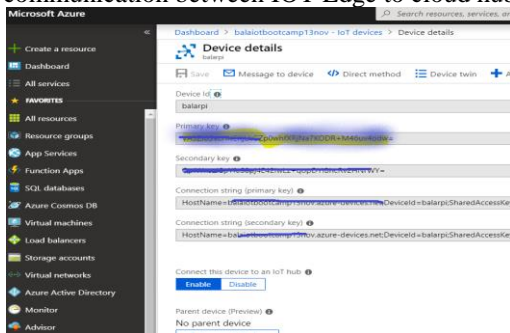

Figure 14. Microsoft Azure- Device details

Data Lake Store:

Based on above cloud store, the data from IOT Hub will be pushed to Azure Data Lake store services and it will be kept as JSON format for better processing in NOSQL database like Cosmos DB.

Visualization: The data available in the NOSQL store will be accessible via visualization tools like Power BI or Tableau which help us to explore the insight from agro plants either real-time or near-real time based on the data refresh frequency. The necessary machine learning model can be plugged along with visualization tools to predict the yield growth.

Mobile Apps: the real-time information will be fetched directly from the drone’s computer via REST API and also the blockchain (Multichain) API’s to get the device specific information.

6. CONCLUSION

The proposed framework use of fog computing paradigm to support the usual cloud layer. Since the vehicles traffic handling is highly time-sensitive application. Fog computing is needed here to reduce end-to-end data communication between the sensors and the cloud. Otherwise, the network traffic will also be high resulting

time delay and poor performance of the system as mentioned in the conventional IoT-based system. If any delay arises during data transmission, the system would not prevent the near future accidents. Road accident seems to occur in various forms and some amount of latency leads to the loss many lives. Such a viable fog computing based intelligent traffic management is required by overcoming the drawbacks of the usual IoT-based model.

REFERENCES

1. Al-Sakran, "Intelligent traffic information system based on the integration of Internet of Things and Agent technology", *International Journal of Advanced Computer Science and Applications (IJACSA)*, vol. 6, no. 2, pp. 37-43, 2015.
2. B. Tang; Z. Chen; G. Hefferman; S. Pei; W. Tao; H. He; Q. Yang, "Incorporating Intelligence in Fog Computing for Big Data Analysis in Smart Cities," in *IEEE Transactions on Industrial Informatics* , vol.PP, no.99, pp.1-1., 2017.
3. D. Puiu et al., "CityPulse: Large Scale Data Analytics Framework for Smart Cities," in *IEEE Access*, vol. 4, no. , pp. 1086-1108, 2016.
4. D. Singh, C. Vishnu and C. K. Mohan, "Visual Big Data Analytics for Traffic Monitoring in Smart City," 2016 15th IEEE International Conference on Machine Learning and Applications (ICMLA), Anaheim, CA, 2016, pp. 886-891.
5. El Fazziki, D. Benslimane, A. Sadiq, J. Ouarzazi and M. Sadgal, "An Agent Based Traffic Regulation System for the Roadside Air Quality Control," in *IEEE Access*, vol. 5, no. , pp. 13192-13201, 2017.
6. H. J. F. Qiu, I. W. H. Ho, C. K. Tse and Y. Xie, "A Methodology for Studying 802.11p VANET Broadcasting Performance With Practical Vehicle Distribution," in *IEEE Transactions on Vehicular Technology*, vol. 64, no. 10, pp. 4756-4769, Oct. 2015.
7. Lusheng Miao, K. Djouani, B. J. Van Wyk and Y. Hamam, "Performance evaluation of IEEE 802.11p MAC protocol in VANETs safety applications," 2013 IEEE Wireless Communications and Networking Conference (WCNC), Shanghai, 2013, pp. 1663-1668.
8. M. M. Islam; M. A. Razzaque; M. M. Hassan; W. Nagy; B. Song, "Mobile Cloud-Based Big Healthcare Data Processing in Smart Cities," in *IEEE Access* , vol.PP, no.99, pp.1-1., 2017.
9. M. V. Moreno et al., "Applicability of Big Data Techniques to Smart Cities Deployments," in *IEEE Transactions on Industrial Informatics*, vol. 13, no. 2, pp. 800-809, April 2017.
10. S.Balachandar , R.Chinnaiyan (2018), Centralized Reliability and Security Management of Data in Internet of Things (IoT) with Rule Builder, *Lecture Notes on Data Engineering and Communications Technologies* 15, 193-201.
11. S.Balachandar , R.Chinnaiyan (2018), Reliable Digital Twin for Connected Footballer, *Lecture Notes on Data Engineering and Communications Technologies* 15, 185-191.
12. S.Balachandar , R.Chinnaiyan (2018), A Reliable Troubleshooting Model for IoT Devices with Sensors and Voice Based Chatbot Application, *International Journal for Research in Applied Science & Engineering Technology*, Vol.6,Iss.2, 1406-1409.
13. M. Swarnamugi ; R. Chinnaiyan, "IoT Hybrid Computing Model for Intelligent Transportation System (ITS)", *IEEE Second International Conference on Computing Methodologies and Communication (ICCMC)*, 15-16 Feb. 2018.

14. M. Swarnamugi; R. Chinnaiyan, "Cloud and Fog Computing Models for Internet of Things", International Journal for Research in Applied Science & Engineering Technology, December 2017.
15. G Sabarmathi, R Chinnaiyan (2019), Envisagation and Analysis of Mosquito Borne Fevers: A Health Monitoring System by Envisagative Computing Using Big Data Analytics, Lecture Notes on Data Engineering and Communications Technologies book series (LNDECT, volume 31), 630-636. Springer, Cham
16. S. Balachandar, R. Chinnaiyan (2019), Internet of Things Based Reliable Real-Time Disease Monitoring of Poultry Farming Imagery Analytics, Lecture Notes on Data Engineering and Communications Technologies book series (LNDECT, volume 31), 615- 620. Springer, Cham
17. M Swarnamugi, R Chinnaiyan (2019), IoT Hybrid Computing Model for Intelligent Transportation System (ITS), Proceedings of the Second International Conference on Computing Methodologies and Communication (ICCMC 2018), 802-806.
18. G. Sabarmathi, R. Chinnaiyan (2016) , Big Data Analytics Research Opportunities and Challenges - A Review, International Journal of Advanced Research in Computer Science and Software Engineering, Vol.6 , Issue.10, 227-231
19. G. Sabarmathi, R. Chinnaiyan, Investigations on big data features research challenges and applications, IEEE Xplore Digital LibraryInternational Conference on Intelligent Computing and Control Systems (ICICCS), 782 – 786.